



pure indoor living



AIR PURIFIER
*WITH AER1™ ALLERGEN
REMOVER FILTERS*

MODEL: BAP1700-CN

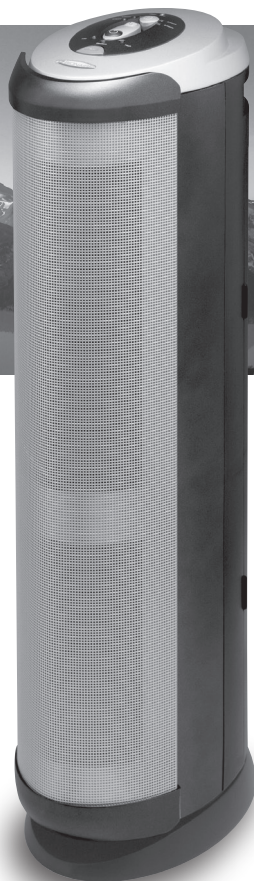

Instruction Leaflet

Read instructions before operating. Retain for future reference.

 Questions? Comments? Call 1-800-253-2764 in North America.

PLEASE READ AND SAVE THESE IMPORTANT SAFETY INSTRUCTIONS

When using electrical appliances, basic safety precautions should always be followed to reduce the risk of fire, electric shock, and injury to persons. These precautions include:

1. Read all instructions before using the appliance.
2. To avoid fire or shock hazard, plug the appliance directly into a 120V AC electrical outlet.
3. If the filter is covered by a bag when shipped, remove plastic bag before use.
4. Keep the cord out of heavy traffic areas. To avoid fire hazard, NEVER put the cord under rugs, near heat registers, radiators, stoves, or heaters.
5. To protect against electrical hazards, DO NOT immerse the appliance in water or other liquids. Do not use near water.
6. Close supervision is necessary when any appliance is used by or near children, or disabled persons.
7. Always unplug the air cleaner before moving or cleaning the unit, opening the grill, changing the filters and whenever the unit is not in use. To disconnect the unit, be sure to pull the plug and not the cord.
8. NEVER drop or insert any objects into the openings of the unit.
9. Do not operate any appliance with a damaged cord or plug. If the motor fan fails to operate or the unit has been dropped or damaged in any manner, return appliance to manufacturer for examination and/or repair.
10. Use appliance only for intended household use as described in this manual. Any other use not recommended by the manufacturer may cause fire, electric shock, or injury to persons. The use of attachments not recommended or sold by Jarden Consumer Solutions may cause hazards.
11. DO NOT use outdoors. Suitable for Dry Location ONLY.
12. NEVER place on a soft surface such as a bed or sofa as this could cause the unit to tip over and block the air inlet or outlet grills.
13. Keep unit away from heated surfaces and open flames.
14. DO NOT attempt to repair or adjust any electrical or mechanical functions on this unit. Doing so will void your warranty. The inside of the unit contains no user serviceable parts. All servicing should be performed by qualified personnel only.
15. **WARNING:** To reduce the risk of fire or electric shock, DO NOT use this appliance with any solid-state speed control device.
16. DO NOT place anything on top of unit.
17. NEVER use detergents, gasoline, glass cleaner, furniture polish, paint thinner, or other household solvents to clean any part of the appliance.
18. Always turn the appliance off before unplugging it.
19. The ionizer may cause a static charge to build up on the air outlet grill. A static charge may be felt if the unit is not properly grounded. To avoid a static charge, plug the unit's three-prong plug into a grounded outlet, or properly install a ground adaptor (see PLUG SAFETY). The static charge will not occur if the ionizer is off.
20. The ionizer in this appliance produces less ozone than the UL established limits of 50ppb. However, in high concentrations, ozone can be harmful to birds and small pets. To prevent ozone buildup, we suggest using the ionizer in well ventilated areas with the fan on.
21. This appliance should only be used in a room with temperatures between 40°F and 110°F.

PLEASE READ AND SAVE THESE IMPORTANT SAFETY INSTRUCTIONS

THIS PRODUCT IS EQUIPPED WITH A 3-PRONG PLUG

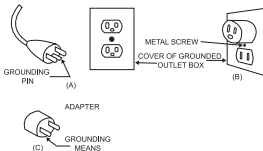

This product is for use on 120 volts. The cord has a plug (A) as shown. An adapter (C) (not included) is available for connecting three-blade grounding-type plugs to two-slot receptacles (B). The green grounding lug extending from the adapter must be connected to a permanent ground such as a properly grounded outlet box. The adapter should not be used if a three-slot grounded receptacle is available.

FEATURES - OPERATIONS

CORD AND PLUG INSTALLATION SAFETY INSTRUCTIONS

The length of cord used on this appliance was selected to reduce the hazards of becoming tangled in, or tripping over a longer cord. If a longer cord is necessary, an approved extension cord may be used. The electrical rating of the extension cord must be equal to or greater than the rating of the air cleaner. Care must be taken to arrange the extension cord so that it will not drape over the countertop or tabletop where it can be pulled on by children or accidentally tripped over. If the supply cord is damaged, it must be replaced by the manufacturer, its service agent or similarly qualified persons in order to avoid hazard.

GET TO KNOW YOUR AIR CLEANER

This unit is compatible with all Aer1™ Filters. This allows you to choose the filter that is just right for you. Below is information on each filter:

- TOTAL AIR** - Advanced Dust Eliminating Technology
- ODOR ELIMINATOR** - 10x the odor fighting power
- ALLERGEN REMOVER** - True HEPA technology improves air quality for allergy sufferers
- GERM REDUCING** - True HEPA PLUS Silver infused germ reducing technology, silver coated filter reduces bacteria and viruses from the air stream.

AIR QUALITY PARTICLE SENSOR

Your Bionaire® Air Cleaner includes a particle sensor that measures indoor air quality. When set to auto mode, it automatically adjusts the fan speed to cycle between low, medium and high speed to provide optimum filtration based on air particulate concentration. It also helps conserve energy by only operating the fan at higher speeds when needed.

IONIZER

This appliance has an optional ionizer feature which, when turned on, releases negative ions into outgoing filtered air to help the air purification process.

What Are Ions?

Ions are tiny particles that carry a positive or negative

charge. They exist naturally around us: in the air, water, and ground. Both positive and negative ions are colorless, odorless, and completely harmless.

How Does The Ionizer Work?

Negative ions help air purification by attaching themselves to very small airborne particles in the room. These particles take on a negative charge and may join with positively charged particles such as dust, pollen, smoke, and pet dander to form larger particles. The larger particles are then more easily captured by the filter system.

Important Notes:

Your ionizer may produce an occasional popping or cracking sound. This is normal and occurs when a small buildup of ions is discharged.

After extended use, you may notice dust around the grills or front panel.

- This is caused by negative ions exiting the air outlet, evidence of the ionizer's air cleaning effectiveness.
- You can remove the dust with a soft brush or clean, damp cloth.

Larger particles may be attracted to positively charged surfaces throughout the home, like walls or floors.

- This may occur more frequently when the filter is nearing the end of its useful product life and unable to capture as many charged particles.
- Excessive amounts of pet dander, dust, or smoke may decrease the life expectancy of the filter(s) and interfere with the ionization process.

To help prevent particles from attracting to surfaces throughout your home:

- You may want to run the ionizer less often.
- Check the condition of the filter(s) more frequently.

CAUTION: The ionizer in this appliance produces less ozone than the UL* established limits of 50ppb. However, in high concentrations, ozone can be harmful to birds and small pets. To prevent ozone buildup, we suggest using the ionizer in well ventilated areas with the fan on.

IMPORTANT: Always check the condition of the Aer1™ filters at the recommended intervals and replace filters if necessary (See FILTER REPLACEMENT INSTRUCTIONS). Using the ionizer with dirty filters may result in dirty particles exiting the air cleaner and attracting to walls, carpets, furniture, or other household objects. These dirty particles may prove difficult to remove.

FEATURES - OPERATIONS

FILTER CHECK INDICATOR

Your Air Cleaner includes Aer1™ Allergen Remover Filters, specially designed to remove pollen, dust, mold and dander and deliver cleaner air for allergy sufferers!! The Aer1™ Allergen Remover Filters last 12 months. See back panel for other filter options.

The Filter Check Indicator is designed to remind you to check and change your filters every 11 months. To reset the Filter Check Indicator, insert a small object such as a pin or paper clip into the hole of the Reset only under working mode. The Filter Check Indicator will be reset (reference FILTERS REPLACEMENT INSTRUCTIONS).

TIMER

The timer allows you to run the air cleaner at your convenience, for up to 8 hours, and automatically turns the power off when time is up, to help reduce energy costs.

HIGH /MEDIUM, AND LOW SPEED SETTINGS

For optimum air filtration, operate your Bionaire® Air Cleaner continuously on the HIGH setting. Its rugged motor has been designed to give many years of use. For quieter operation (such as in a bedroom), select LOW setting.

BEFORE USE

1. Carefully unpack your air cleaner.
2. Select a firm, level surface with no obstructions to the air inlets or outlets.
3. Access your Aer1™ Filters. If the filters are covered by bags when shipped, remove plastic bags before use and place filters into unit. (Reference FILTER REPLACEMENT INSTRUCTIONS).

OPERATING INSTRUCTIONS

IMPORTANT:

- Remove all plastic bags from filters before use.
- DO NOT POINT FILTERED AIR OUTLET TOWARDS WALL.

To operate your air cleaner:

1. Plug into a 120V AC electrical outlet.
2. Press the POWER (⏻) button. The air cleaner will turn on at LOW filtering speed.

3. Select filtering speed by pressing POWER button until you reach the desired speed - HIGH, MEDIUM or LOW. The air cleaner will turn off when you press the POWER button for 3 seconds at any speed.
4. Press IONIZER (⊗) button to turn ionizer ON or OFF. IONIZER button works in any mode except when air cleaner is turned off.

AIR QUALITY PARTICLE SENSOR

The AUTO feature uses the particle sensor to cycle between low, medium and high speeds, based on surrounding indoor air quality. To use this feature:

Figure 1

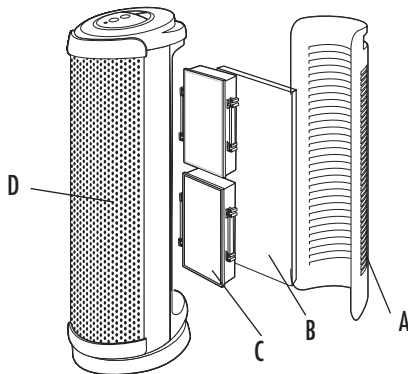
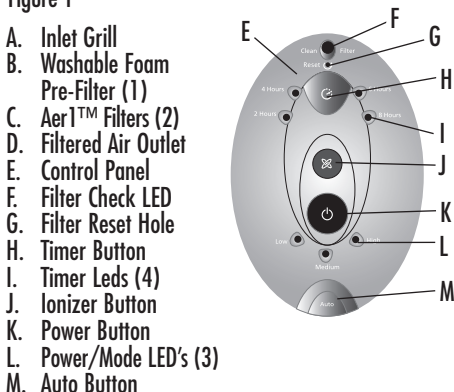

CLEANING AND MAINTENANCE

1. When air cleaner is off, press the AUTO button. The button will illuminate and the air cleaner will turn on to auto mode.
2. When air cleaner is on and set at any manual mode speed, press the “auto” button. The button will illuminate and the air cleaner will run in auto mode.

SETTING THE TIMER MODE

You may set the timer so it automatically turns off when the desired time has elapsed:

1. Press the TIMER (⌚) button until you reach the desired number of hours you want the unit to operate (2, 4, 6 or 8).
2. The number of hours selected will light up and remain illuminated on the control panel.
3. When time is up, the air cleaner will turn off.
4. To CANCEL the timer, press the TIMER button until TIMER indicator lights are off. You may also cancel the timer operation by turning the power button off.

CLEANING AND MAINTENANCE

Cleaning the unit:

1. Turn off and unplug the air cleaner.
2. The outside of the unit can be cleaned with a soft, clean dampened cloth.
3. The air inlet grill (see figure 1) can be cleaned with a soft, clean damp cloth.
4. The filtered air outlet can be cleaned of dust with a small soft brush.
5. If you wish to clean the inside of the air cleaner, please only use a dry, soft cloth to wipe it down. DO NOT WASH the Aer1™ filters. The Pre-filter (B) can be washed by using a mild dish soap and water. Rinse thoroughly. Allow to air dry completely prior to reinstalling into the Air Inlet Grill (A).
6. NEVER use detergents, gasoline, glass cleaner, furniture polish, paint thinner or other household solvents to clean any part of the air cleaner.

WARNING: Do not allow moisture to come in contact with the main housing of the air cleaner.

FILTER REPLACEMENT INSTRUCTIONS

Every few weeks, check the condition of filters. Filter life

will vary, depending on air quality and usage (see below). Under normal conditions of continuous use, the Aer1™ Total Air and Odor Filter will last 4 months while the Allergen and Germ Filter will last 12 months. After approximately 11 months of operation, the Filter Check Indicator Light (☉) will illuminate to alert you to service the filter:

- Filters with a 4-month filter life: This Filter Check indicator is to remind you to perform maintenance to wipe your unit clean, wash the foam pre-filter and to replace the Aer1™ filters.
- Filters with a 12 month filter life: This filter Check indicator is to remind you to perform annual maintenance to wipe your unit clean, wash the foam pre-filter and to replace the Aer1™ filters.

To replace your filter:

1. Turn off and unplug the air cleaner before attempting to replace the filters.
2. Remove each of the filters from the unit by pulling them gently towards you.
3. Discard the Aer1™ filters. DO NOT attempt to clean them.
4. Remove protective plastic bags and install new Aer1™ filters into the unit.

NOTE: A hang tab and filter clips ensure the filter attaches properly.

1. Make sure the hang tab is securely in place. Align the clip on the top of the filter with the rails on the inside of the unit. Gently slide the filter onto the rail (see Figures 2 and 3).
2. Place air inlet grill back onto unit securely.
3. After replacing the filters, RESET the Filter Check Indicator (☉) by inserting a small object (such as a pin or paper clip) into the hole below the Filter Check light (see Figure 4). The light will go off.

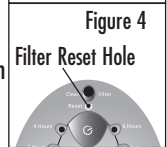
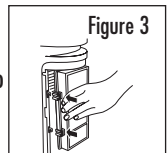
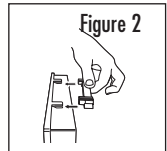

TROUBLESHOOTING

FILTERS CAN BE PURCHASED ONLINE AT WWW.BIONAIRECANADA.COM.

Air Purifier Model #	Filter Quantity Needed	Compatible with all filter models below	Filter Description
BAP1700-CN	1	BAPF30AT BAPF30AO BAPF350AG BAPF300AH BAPF30 (A filter)	Aer1™ Total Air Filter Aer1™ Odor Filter Aer1™ Germ Filter Aer1™ Allergen Remover Filter Bionaire® "A" Filter

TIPS AND TROUBLESHOOTING

ISSUE	SOLUTION
• UNIT WILL NOT OPERATE.	✓ Make sure unit is properly plugged in and outlet is energized. ✓ Make sure unit turned ON.
• DECREASED AIR FLOW.	✓ Make sure nothing is blocking air inlet and filtered air outlets. ✓ Remove all plastic bags from filters. ✓ Check condition of filters and replace if necessary. ✓ Make sure that the air intake grill is at least 1 to 3 feet from away the wall. ✓ When unit operates in the AUTO mode, it will automatically adjust the fan speed to provide optimum filtration based on air particulate concentration. Therefore, depending on the air quality in the room, some variation in air flow is normal and expected.
• EXCESSIVE NOISE.	✓ Remove plastic bag(s) from filter(s). ✓ Make sure parts are firmly positioned in place.

If you have any questions regarding your product or would like to learn more about other Bionaire® products, please contact our Consumer Service Department at 1-800-253-2764 or visit our website at www.bionairecanada.com.

WARRANTY INFORMATION

5 YEAR LIMITED WARRANTY

Sunbeam Products, Inc. doing business as Jarden Consumer Solutions or if in Canada, Sunbeam Corporation (Canada) Limited doing business as Jarden Consumer Solutions (collectively "JCS") warrants that for a period of five years from the date of purchase, this product will be free from defects in material and workmanship. JCS, at its option, will repair or replace this product or any component of the product found to be defective during the warranty period.

Replacement will be made with a new or remanufactured product or component. If the product is no longer available, replacement may be made with a similar product of equal or greater value. This is your exclusive warranty. Do NOT attempt to repair or adjust any electrical or mechanical functions on this product. Doing so will void this warranty.

This warranty is valid for the original retail purchaser from the date of initial retail purchase and is not transferable. Keep the original sales receipt. Proof of purchase is required to obtain warranty performance. JCS dealers, service centers, or retail stores selling JCS products do not have the right to alter, modify or any way change the terms and conditions of this warranty.

This warranty does not cover normal wear of parts or damage resulting from any of the following: negligent use or misuse of the product, use on improper voltage or current, use contrary to the operating instructions, disassembly, repair or alteration by anyone other than JCS or an authorized JCS service center. Further, the warranty does not cover: Acts of God, such as fire, flood, hurricanes and tornadoes.

What are the limits on JCS's Liability?

JCS shall not be liable for any incidental or consequential damages caused by the breach of any express, implied or statutory warranty or condition.

Except to the extent prohibited by applicable law, any implied warranty or condition of merchantability or fitness for a particular purpose is limited in duration to the duration of the above warranty.

JCS disclaims all other warranties, conditions or representations, express, implied, statutory or otherwise.

JCS shall not be liable for any damages of any kind resulting from the purchase, use or misuse of, or inability to use the product including incidental, special, consequential or similar damages or loss of profits, or for any breach of contract, fundamental or otherwise, or for any claim brought against purchaser by any other party.

Some provinces, states or jurisdictions do not allow the exclusion or limitation of incidental or consequential damages or limitations on how long an implied warranty lasts, so the above limitations or exclusion may not apply to you.

This warranty gives you specific legal rights, and you may also have other rights that vary from province to province, state to state or jurisdiction to jurisdiction.

How to Obtain Warranty Service

In the U.S.A.

If you have any question regarding this warranty or would like to obtain warranty service, please call 1-800-253-2764 and a convenient service center address will be provided to you.

In Canada

If you have any question regarding this warranty or would like to obtain warranty service, please call 1-800-253-2764 and a convenient service center address will be provided to you.

In the U.S.A., this warranty is offered by Sunbeam Products, Inc. doing business as Jarden Consumer Solutions located in Boca Raton, Florida 33431. In Canada, this warranty is offered by Sunbeam Corporation (Canada) Limited doing business as Jarden Consumer Solutions, located at 20 B Hereford Street, Brampton, Ontario L6Y 0M1. If you have any other problem or claim in connection with this product, please write our Consumer Service Department. **PLEASE DO NOT RETURN THIS PRODUCT TO ANY OF THESE ADDRESSES OR TO THE PLACE OF PURCHASE.**

AER1™ SERIES FILTERS

CONGRATULATIONS! YOUR NEW AIR CLEANER IS EQUIPPED WITH THE NEW AND IMPROVED AER1™ ALLERGEN REMOVER FILTERS.

Filter Type	Technology	Consumer Benefit
Total Air	99% HEPA-Type technology. Infused with Arm & Hammer® baking soda. Infused with silver technology.	Ideal for dust reduction. Delivers 30% better air quality.
Odor Eliminator	10 times the odor fighting power. Contains Arm & Hammer® baking soda, carbon and zeolite for odor control.	Ideal for eliminating odors from pets, tobacco smoke and cooking fumes.
THIS UNIT COMES WITH Allergen Remover	99.97% True HEPA technology. Removes up to 99.97% of particales passing through the filter such as pollen, dust, mold and dander.	Ideal for allergy sufferers.
Germ Fighter with Allergen Remover	99.97% True HEPA technology. Infused with silver technology.	Helps reduce viruses and bacteria as well as ideal for allergy sufferers.

