



pure indoor living



Remote Control
TOWER FAN

MODEL: BTF4011AR-CN

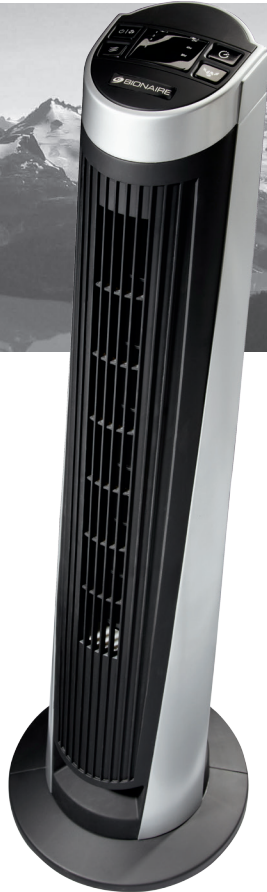

Instruction Leaflet

Read instructions before operating. Retain for future reference.

 Questions? Comments? Call 1-800-253-2764 in North America or visit our website at www.bionairecanada.com.

PLEASE READ AND SAVE THESE IMPORTANT SAFETY INSTRUCTIONS

When using electrical appliances, basic safety precautions should always be taken including the following:

1. Read all instructions before using this appliance.
2. Use fan only for purposes described in the instruction manual.
3. To protect against electrical shock do not immerse unit, adapter or cord in water or spray with liquids and plug the adapter directly into a 120V AC electrical outlet.
4. Close supervision is necessary when any appliance is used by or near children.
5. Unplug from outlet when not in use, when moving fan from one location to another, before putting on or taking off parts and before cleaning.
6. Avoid contact with moving parts.
7. Do not operate in the presence of explosive and/or flammable fumes.
8. To avoid fire hazard, NEVER place the cord under rugs or any parts near an open flame, cooking or other heating appliance.
9. Do not operate any appliance with a damaged cord or adapter after the appliance malfunctions, or has been dropped/damaged in any manner. Discard fan or return to an authorized service facility for examination and/or repair.
10. Do not run cord under carpeting. Do not cover cord with throw rugs, runner, or similar coverings. Do not route cord under furniture or appliances. Arrange cord away from traffic area and where it will not be tripped over.
11. The use of attachments not recommended or sold by the appliance manufacturer may cause hazards.
12. Do not let the cord hang over the edge of a table, counter or come in contact with hot surfaces or leave exposed to high traffic areas.
13. Do not use outdoors.
14. To disconnect, grip adapter and pull from wall outlet. Never yank on cord.
15. Always use on a dry, level surface.
16. Do not operate fan until fully assembled with all parts properly in place.
17. This product is intended for household use ONLY and not for commercial or industrial applications.
18. **WARNING:** To reduce the risk of electrical shock and injury to persons, do not use in window.
19. **WARNING:** To reduce the risk of fire or electric shock, do not use this fan with any solid-state speed control device.

PLEASE READ AND SAVE THESE IMPORTANT SAFETY INSTRUCTIONS

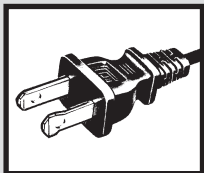

THIS APPLIANCE HAS A POLARIZED PLUG (ONE BLADE IS WIDER THAN THE OTHER). TO REDUCE THE RISK OF ELECTRIC SHOCK, THIS PLUG IS INTENDED TO FIT IN A POLARIZED OUTLET ONLY ONE WAY. IF THE PLUG DOES NOT FIT FULLY IN THE OUTLET, REVERSE THE PLUG. IF IT STILL DOES NOT FIT, CONTACT A QUALIFIED ELECTRICIAN TO INSTALL THE PROPER OUTLET.

DO NOT ATTEMPT TO MODIFY THIS PLUG OR DEFEAT THIS SAFETY FEATURE IN ANY WAY.

FEATURES - OPERATIONS

INSTALLATION INSTRUCTION: (SEE FIGURE 1)

Figure 1

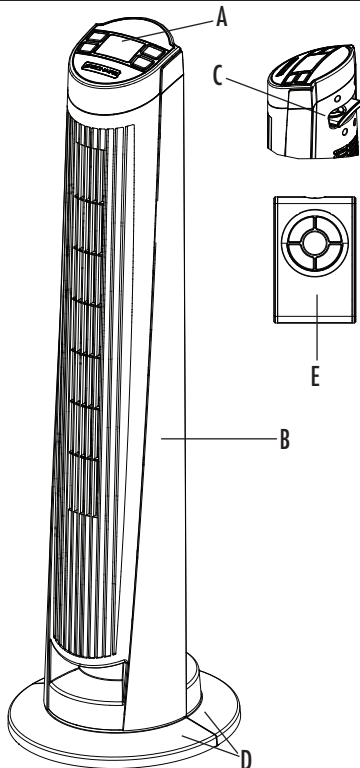

- | | |
|---------------------------|-------------------|
| A. Control Panel | D. Base Halves |
| B. Fan Housing | E. Remote Control |
| C. Remote Control Storage | |

Figure 2

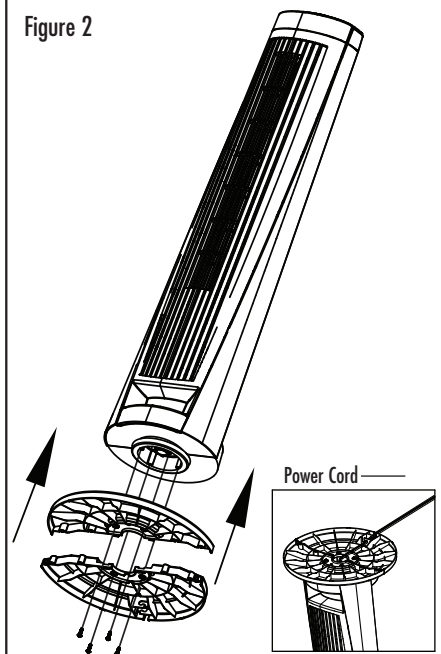

2. Line up the screws holes of the base halves with the holes located on the bottom of the fan housing. Secure with the four screws included with the product. Refer to Figure 2.
3. Run the Power Cord through the cord channel located underneath the base. Refer to Figure 2.
4. Turn fan right side up and place on a dry and level surface.

ASSEMBLY INSTRUCTIONS: (SEE FIGURE 2)

Estimated assembly time: 5-10 minutes
(tools required: Screwdriver)

NOTE: MAKE SURE YOU REMOVE ALL CONTENTS FROM THE PACKAGE. PLEASE CHECK PACKAGING MATERIALS FOR PARTS THAT COULD BE REQUIRED TO OPERATE YOUR FAN.

1. Assemble base halves around power cord. To secure the base halves together, slide the posts of one base half into the slots of the second base half. Refer to Figure 2.

OPERATING INSTRUCTIONS: (SEE FIGURE 3, 4)

1. To turn the fan on, press the power/speed button (⏻/⏻) located on the control panel or press the power button (⏻) on the remote control.
2. The fan will run at the lowest speed setting (1). To cycle through to higher speed settings (2-3-4-5), press the power/speed button (⏻/⏻) located on the control panel or press the speed button (⏻) on the remote control. The corresponding indicator light will illuminate to indicate which setting is selected.

FEATURES - OPERATIONS

Figure 3
Control Panel

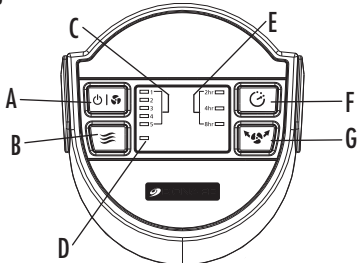

- A. Power/Speed Button (⏻/⏻)
- B. Breeze Button (🌀)
- C. Speed Indicator Lights(1-5)
- D. Breeze Mode Indicator Light
- E. Timer Indicator Lights (2hr/4hr/8hr)
- F. Timer Button (⌚)
- G. Oscillation Button (↔)

3. To turn the oscillation on and off, press the oscillation button(↔) located on the control panel or remote control.
4. To set your fan to automatically shut off, press the timer button(⌚) located on the control panel or the remote control. When set, the fan will run and automatically shut off after the set duration of time (2, 4, or 8 hours) has expired.
5. To activate the breeze mode, press the breeze button (🌀) located on the control panel or remote control. When turned on, the fan will randomly cycle through the five speeds settings recreating a natural outdoor breeze.
6. To turn the fan off, press and hold the power/speed button(⏻/⏻) for 3 seconds located on the control panel or press the power button (⏻) once on the remote control.

NOTE: Your fan features LED indicator lights. When a specific feature is activated on your fan, a corresponding LED indicator light will illuminate showing which features have been activated.

REMOTE CONTROL HANDSET

NOTE: PLEASE REMOVE THE PROTECTIVE STICKER FROM THE REMOTE CONTROL BATTERY BEFORE OPERATION.

This unit includes one lithium battery, CR2025/3V.

Figure 4
Remote Control

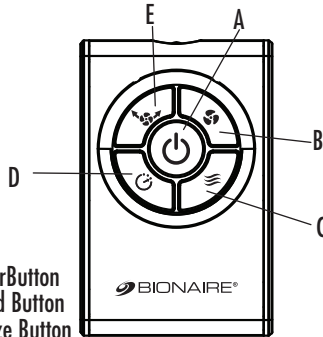

- A. PowerButton
- B. Speed Button
- C. Breeze Button
- D. Timer Button
- E. Oscillation Button

Remove battery before discarding the remote.

Battery Replacement

- a) Locate the battery compartment on the back of the remote control handset. Slide the battery cover out with your thumb.
- b) Remove old battery.
- c) Place new battery into battery compartment.
- d) Slide battery compartment into the remote control handset.

NOTES:

- THIS PRODUCT CONTAINS A BUTTON BATTERY. IF SWALLOWED, IT COULD CAUSE SEVERE INJURY IN JUST 2 HOURS. SEEK MEDICAL ATTENTION IMMEDIATELY.
- Remove the battery from the equipment when it is not being used for an extended period of time.
- Remove the used battery promptly.
- Do not discard used batteries into household trash containers. Contact your local government for disposal or recycling practices in your area.

This Class B digital apparatus complies with Canadian ICES-003.

FEATURES - OPERATIONS

CLEANING/MAINTENANCE INSTRUCTIONS

Follow these instructions to correctly and safely care for your fan. Please remember:

FAN CLEANING

- Always unplug the fan before cleaning.
- Do not allow water to drip on or enter into fan housing.
- Be sure to use a soft cloth moistened with a mild soap solution.
- Do not use gasoline, thinner or benzene as a cleaner.
- We also recommend the periodic cleaning of this fan by lightly running a vacuum cleaner nozzle over the fan grill to remove any dust or dirt that may have accumulated inside or on the unit.

FAN STORAGE

When storing your fan in the off season, it is important to keep it in a safe dry location. It is important to protect the fan head from dust.

If you have any questions regarding your product or would like to learn more about other Bionaire® products, please contact our Consumer Service Department at 1-800-253-2764 or visit our website at www.bionairecanada.com.

WARRANTY INFORMATION

1 YEAR LIMITED WARRANTY

Sunbeam Products, Inc. doing business as Jarden Consumer Solutions or if in Canada, Sunbeam Corporation (Canada) Limited doing business as Jarden Consumer Solutions (collectively "JCS") warrants that for a period of one year from the date of purchase, this product will be free from defects in material and workmanship. JCS, at its option, will repair or replace this product or any component of the product found to be defective during the warranty period. Replacement will be made with a new or remanufactured product or component. If the product is no longer available, replacement may be made with a similar product of equal or greater value. This is your exclusive warranty. Do NOT attempt to repair or adjust any electrical or mechanical functions on this product. Doing so will void this warranty.

This warranty is valid for the original retail purchaser from the date of initial retail purchase and is not transferable. Keep the original sales receipt. Proof of purchase is required to obtain warranty performance. JCS dealers, service centers, or retail stores selling JCS products do not have the right to alter, modify or any way change the terms and conditions of this warranty.

This warranty does not cover normal wear of parts or damage resulting from any of the following: negligent use or misuse of the product, use on improper voltage or current, use contrary to the operating instructions, disassembly, repair or alteration by anyone other than JCS or an authorized JCS service center. Further, the warranty does not cover: Acts of God, such as fire, flood, hurricanes and tornadoes.

What are the limits on JCS's Liability?

JCS shall not be liable for any incidental or consequential damages caused by the breach of any express, implied or statutory warranty or condition.

Except to the extent prohibited by applicable law, any implied warranty or condition of merchantability or fitness for a particular purpose is limited in duration to the duration of the above warranty.

JCS disclaims all other warranties, conditions or representations, express, implied, statutory or otherwise.

JCS shall not be liable for any damages of any kind resulting from the purchase, use or misuse of, or inability to use the product including incidental, special, consequential or similar damages or loss of profits, or for any breach of contract, fundamental or otherwise, or for any claim brought against purchaser by any other party.

Some provinces, states or jurisdictions do not allow the exclusion or limitation of incidental or consequential damages or limitations on how long an implied warranty lasts, so the above limitations or exclusion may not apply to you.

This warranty gives you specific legal rights, and you may also have other rights that vary from province to province, state to state or jurisdiction to jurisdiction.

How to Obtain Warranty Service

In the U.S.A.

If you have any question regarding this warranty or would like to obtain warranty service, please call 1-800-253-2764 and a convenient service center address will be provided to you.

In Canada

If you have any question regarding this warranty or would like to obtain warranty service, please call 1-800-253-2764 and a convenient service center address will be provided to you.

In the U.S.A., this warranty is offered by Sunbeam Products, Inc. doing business as Jarden Consumer Solutions located in Boca Raton, Florida 33431. In Canada, this warranty is offered by Sunbeam Corporation (Canada) Limited doing business as Jarden Consumer Solutions, located at 20 B Hereford Street, Brampton, Ontario L6Y 0M1. If you have any other problem or claim in connection with this product, please write our Consumer Service Department. **PLEASE DO NOT RETURN THIS PRODUCT TO ANY OF THESE ADDRESSES OR TO THE PLACE OF PURCHASE.**